

BRAVA

*** **MCF** ITALY SYSTEMS ***
CONCRETE MIXERS
WWW.MCFSYSTEMS.IT



MADE IN ITALY



Turbo mixer type



Planetary mixer type

Technical features

PAN OR PLANETARY MIXER

Mixing system with turbo or planetary mixer according to the customer needs.

GROUND BUCKET

Loading system with ground bucket entirely covered with grids.

MIXER SUPPORT STRUCTURE

Structure of support realized for an easy installation on site.

CONTROL PANEL

Manual management of commands that ensures the ease of use.

Key points

- ✓ **Fast installation:** The plant is ready for the immediate use.
- ✓ **Compactness:** Ideal plant to overcome the functional and dimensional difficulties of the construction site.
- ✓ **Easy-to-Use:** Of easy use, equipped with a manual control system.
- ✓ **Adaptability:** It's suitable for all fields of use of concrete particularly indicated for building companies.

Configurations

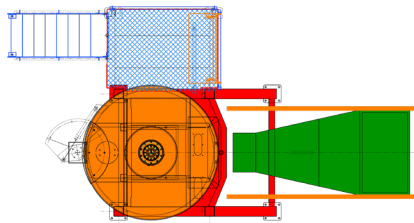
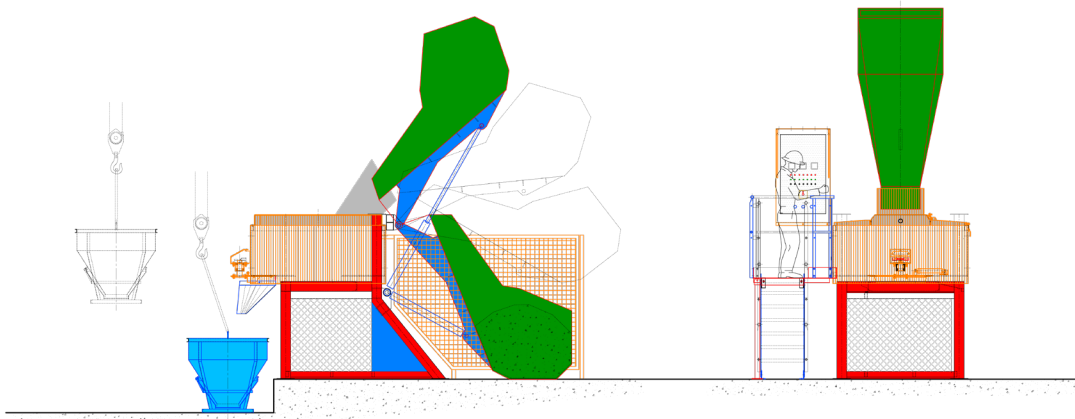

Pan

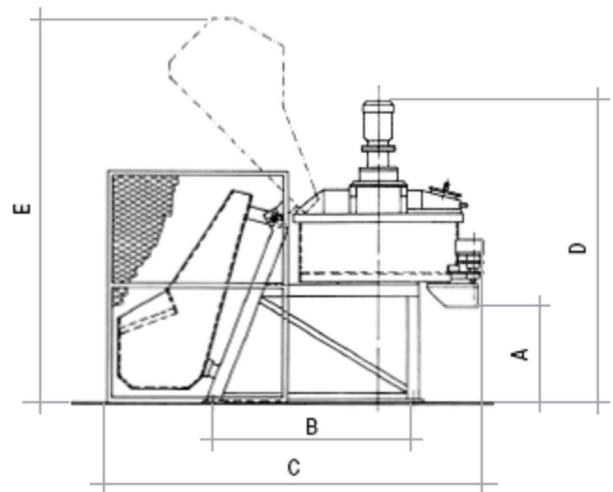

Planetary

BRAVA: PLANETARY		P 300	P 400	P 500
Tank capacity	lt	800	900	1100
Fresh concrete	lt	300	400	500
Installed power	kW	11	12,5	16,5
Discharge height	mt	1,2	1,2	1,2

BRAVA: PAN		T 300	T 400	T 500
Tank capacity	lt	600	760	760
Fresh concrete	lt	300	400	500
Installed power	kW	11	12,5	16,5
Discharge height	mt	1,2	1,2	1,2